XML / HTTP(s)

NETIO M2M API protocols docs

Protocol version: XML Version 2.4

Document published: 20.07.2021

Short summary

XML / HTTP(s) protocol is a file-based M2M API protocol, where the NETIO device is a HTTP(s) server and the client downloads or uploads one text file document in the xml format to control the NETIO power outputs (230V power sockets or IEC-320 power outlets 110/230V).

- For listed NETIO devices, the protocol also includes power consumption values.
- The XML protocol must be enabled first in the WEB configuration of the respective device. For details, see the “NETIO WEB configuration” chapter.
- This protocol is HTTP(s) based. If you want to use different port that is used for device web configuration, you can enable and use the M2M HTTP(s) port.
- Username and password to access the file is hidden in the HTML header. There can be different username & password for the read and write access.
- With write (netio.xml file upload by http post) the device send you back the current (updated) xml answer content in the same structure as the netio.xml file.

Supported devices

NETIO 4x Linux based devices: networked power sockets with LAN / WiFi connectivity.

- NETIO PowerPDU 4C
- NETIO 4, 4All (obsolete products)

NETIO 4x firmware – 3.0.1 and later

Standard NETIO devices: networked power sockets with LAN / WiFi connectivity.

- NETIO **PowerCable REST 101x** (*Energy metering*)
- NETIO **PowerBOX 3Px**
- NETIO **PowerBOX 4Kx** (*Energy metering*)
- NETIO **PowerDIN 4PZ** (*Energy metering*)
- NETIO **PowerPDU 4PS**
- NETIO **PowerPDU 8QS** (*Energy metering*)

Note: Firmware – 3.1.3 and later

Note: This document provides basic info about the M2M API protocol. Other device functions are described in the product manual.

Quick start with XML & NETIO

- **READ function - status**

Read a XML file from your NETIO by HTTP(s) **GET**: [http\(s\)://<netioIP>/netio.xml](http(s)://<netioIP>/netio.xml)
Example: <http://192.168.1.1/netio.xml>

- **WRITE function - control**

Upload the following XML file by HTTP(s) **POST** to: [http\(s\)://<netioIP>/netio.xml](http(s)://<netioIP>/netio.xml)
Example: <http://192.168.1.1/netio.xml>

XML file (command to switch Power output 1 to ON):

```
<set:Root xmlns:set="http://www.netio-products.com/XMLSchema/NETIO.xsd">
  <Outputs>
    <Output>
      <ID>1</ID>
      <Action>1</Action>
    </Output>
  </Outputs>
</set:Root>
```

If the XML & command is accepted, then NETIO returns HTTP Status Code "200 OK" and answer with the XML content (identical to netio.xml file).

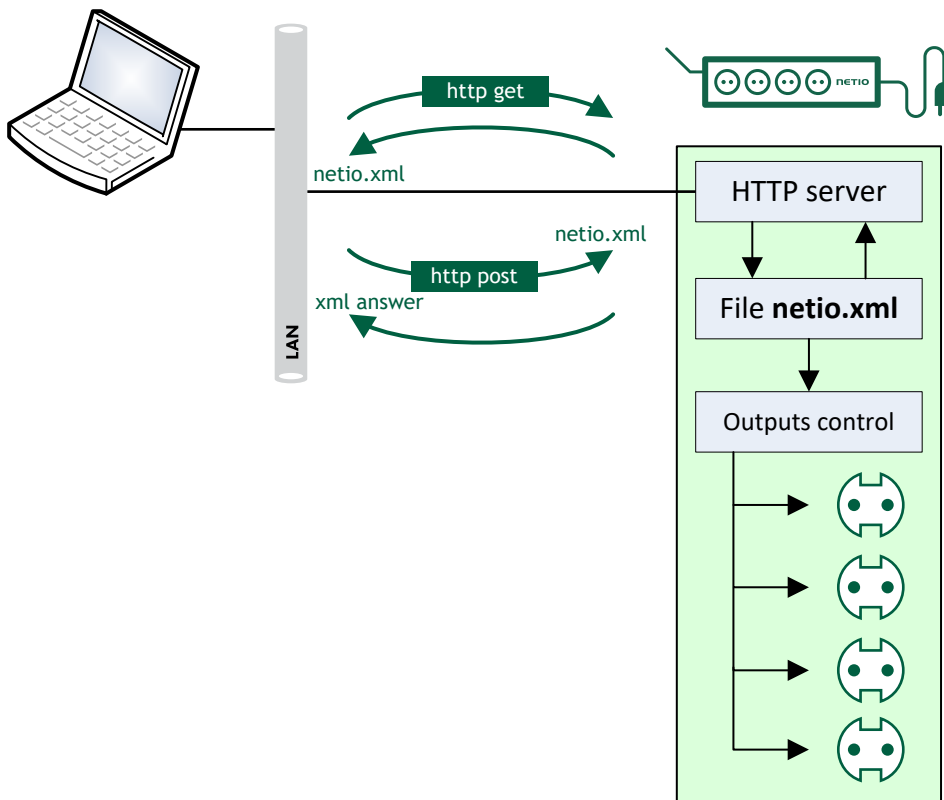

HTTP(s) options

Most of the NETIO devices **do not support** HTTPS protocol

- NETIO **PowerCable REST 101x**
- NETIO **PowerPDU 2Kx**
- NETIO **PowerPDU 2Px**
- NETIO **PowerBOX 3Px**
- NETIO **PowerBOX 4Kx**
- NETIO **PowerDIN 4PZ**
- NETIO **PowerPDU 4Px**
- NETIO **PowerPDU 4Kx**
- NETIO **PowerPDU 8Qx**
- NETIO **PowerPDU 8Kx**

NETIO PowerPDU 4C

There are 2 different HTTP(s) ports:

- 1) The web administration of the device - HTTP(s).
Web administration is in the Settings/System (HTTP) or System/Security Settings (HTTPS).
- 2) Separated HTTP(s) port for the M2M API protocols (XML, JSON, URL API).
Web administration is in each M2M API protocol settings.

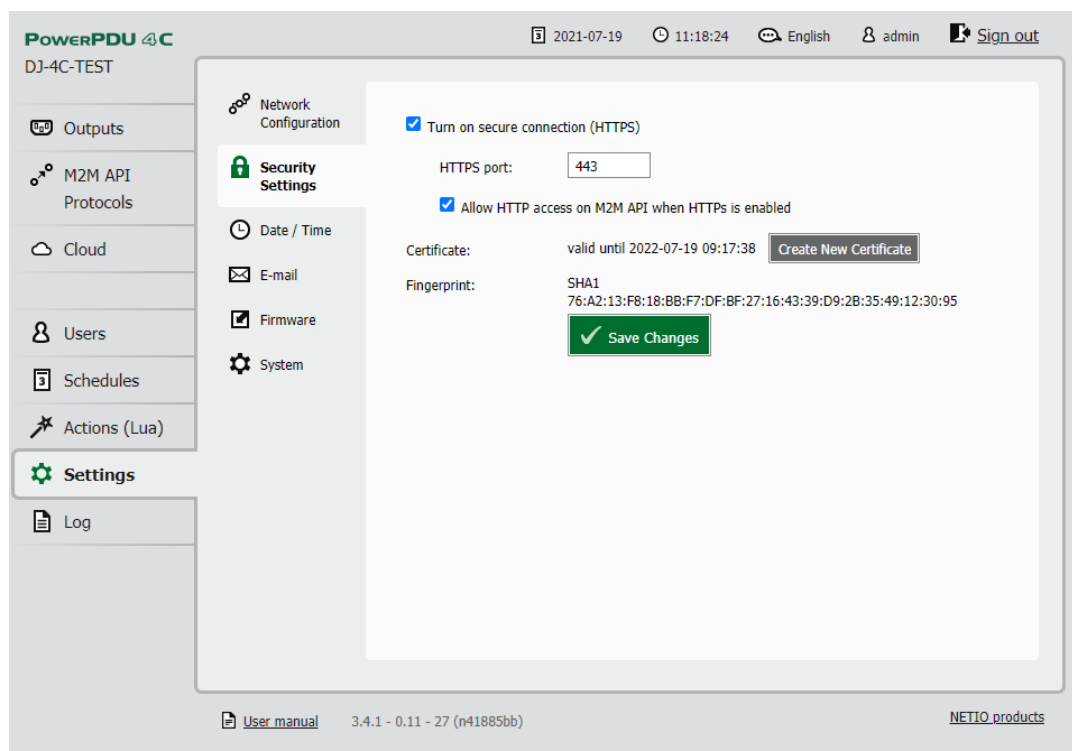

-
- All HTTP(s) protocols (XML / JSON / URL-API) share one HTTP(s) port.
 - For PowerPDU 4C have to be both ports (for web + URL API) **http** or **https**.
 - Custom HTTPS certificate is not supported.

General NETIO output functions

Output status – “read” function

- **0** – Power **OFF**
- **1** – Power **ON**

Output Actions – “write” function

- **0** – Turn **OFF**
- **1** – Turn **ON**
- **2** – Short OFF delay (restart)
- **3** – Short ON delay
- **4** – **Toggle** (invert the state)
- **5** – No change to this one output
- **6** – Ignored (return value from reading the tag)
Current output value is in the “State” tag (0 / 1).

Short ON / OFF delay

This command switches a power output On / Off for a defined time. It is useful for example to power-cycle a server with a defined switch-off time, or to switch on a pump for a defined time.

This “short” delay is protected: the power output will remain in the defined state regardless of any other M2M requests received. During this time, the output state can only be changed by pressing the button on the NETIO device and this action cancel M2M short ON/OFF command for the particular output. Other requests to control the particular output are simply ignored and an ERROR logged with reason rejected in a device Log.

The short ON / OFF delay interval can be defined in the device web administration. It is specified in ms (milliseconds) and rounded up to hundreds of milliseconds (0,1s).

This interval can be also defined using some M2M API protocol commands. In that case, it is valid only for a single protocol session (the following short ON / Short OFF command). When the connection is closed or restarted, the interval is reset to the device default value (defined in the web administration for each output).

Security issues

Do not use default usernames and passwords! Keep your Ethernet and WiFi networks secured.

Power-Up outputs state

After connecting the NETIO device to power grid, all outputs are set to the selected state based on its individual settings:

- **LAST state**
After a power outage, the NETIO device sets the power output to the **last stored state** of this one output.
- **ON**
The output is turned ON.
- **OFF**
The output stays OFF.

Note: The function **Scheduler** is checked during Power-Up initialization. When enabled, it can affect one or more power output states based on current time and week-day.

Custom based **Lua scripts** can affect output states too.

General NETIO DI (Digital Inputs) read features

Digital Input status

- **0** – “open” / **ON**
- **1** – “closed” / **OFF**

S0 counters

- 4Bytes counted number of S0 impulses / “ON” pulses

General NETIO Counters

- Power consumption counters can be reset to 0 manually
- Power consumption NR counters are Not Resettable
- S0 pulse counters on DI (Digital Inputs) can be reset to 0 manually

- All counters are not affected by power outage.

How to reset counters to 0

Click to button in the device settings. It will reset the counters.

The screenshot shows the web interface for a PowerPDU-F3 device. The left sidebar contains navigation options: Outputs, Inputs, M2M API Protocols, Cloud, Users, Schedules, Settings (highlighted), and Log. The main content area is titled 'System' and displays various configuration options. A red box highlights the 'Reset Power Consumption Counters' button. Other visible buttons include 'Locate', 'Restore Factory Defaults', 'Export configuration', and 'Import configuration'. The 'Save Changes' button is also visible.

PowerPDU 8QS
PowerPDU-F3

2021-06-17 18:02:05 integrations Sign out

Network Configuration
Date / Time
Firmware
System

Uptime: 6 hours 50 minutes 21 sec
Firmware version: 3.1.6 - 1.47(1.47) - 0 SN: 24A42C399FF3 Upgrade
Device name: PowerPDU-F3
HTTP port: 12380
 Enable Periodic device restart
Restart period: 1440 minutes, does not affect the Output state
Debug Log:

Save Changes

Locate Blink with status LEDs for 1 minute.

Reset Power Consumption Counters

Restore Factory Defaults

Export and import device configuration
Configuration file: Browse... No file selected. Export configuration Import configuration

Product manual NETIO products a.s. 3.1.6 - 1.47(1.47) - 0 SN: 24A42C399FF3 (cfa2198)

Energy metering variables

Energy metering is available for:

- NETIO PowerPDU 4C
- PowerCable REST
- PowerBox 4Kx
- PowerDIN 4PZ
- PowerPDU 8QS

Parameters for the **whole NETIO device**:

Variable	Unit	Description
Voltage	V	Instantaneous voltage
Frequency	Hz	Instantaneous frequency
Total Current	mA	Instantaneous total current through all power outputs
Total Power Factor	-	Instantaneous True Power Factor – weighted average from all meters
Total Phase	°	Instantaneous True Phase – weighted average from all meters
Total Load	W	Total load (power) of all power outputs (device's own internal consumption is not included)
Total Energy	Wh	Total Counter of consumed Energy (resettable)
Total Energy NR	Wh	Not Resettable counter of total consumed Energy
Total Reverse Energy	Wh	Counter of Reversed (produced) Energy (resettable)
Total Reverse Energy NR	Wh	Not Resettable counter of total Reversed Energy
Energy Start	-	Date and time of the last reset of all energy counters
<i>Overall True Power Factor</i>		<i>Historical compatibility only, do not use it.</i>
<i>Overall Phase</i>		<i>Historical compatibility only, do not use it.</i>

Parameters for **each power output**:

Variable	Unit	Description
Power Factor	-	TPF True Power Factor for the output
Phase	°	Phase for the specific power output
Load	W	Instantaneous load (power) for the specific power output.
Current	mA	Electric current for the output
Energy	Wh	Counter of Energy consumed per output (resettable)
Reverse Energy	Wh	Counter of Energy produced per output (resettable)
Energy NR	Wh	Not Resettable counter of output consumed Energy
Reverse Energy NR	Wh	Not Resettable counter of Reversed (produced) Energy

NETIO WEB configuration

M2M API protocols can be enabled and configured only over the web administration – select “M2M API Protocols” in the left-hand side menu and then select the “XML API” tab.

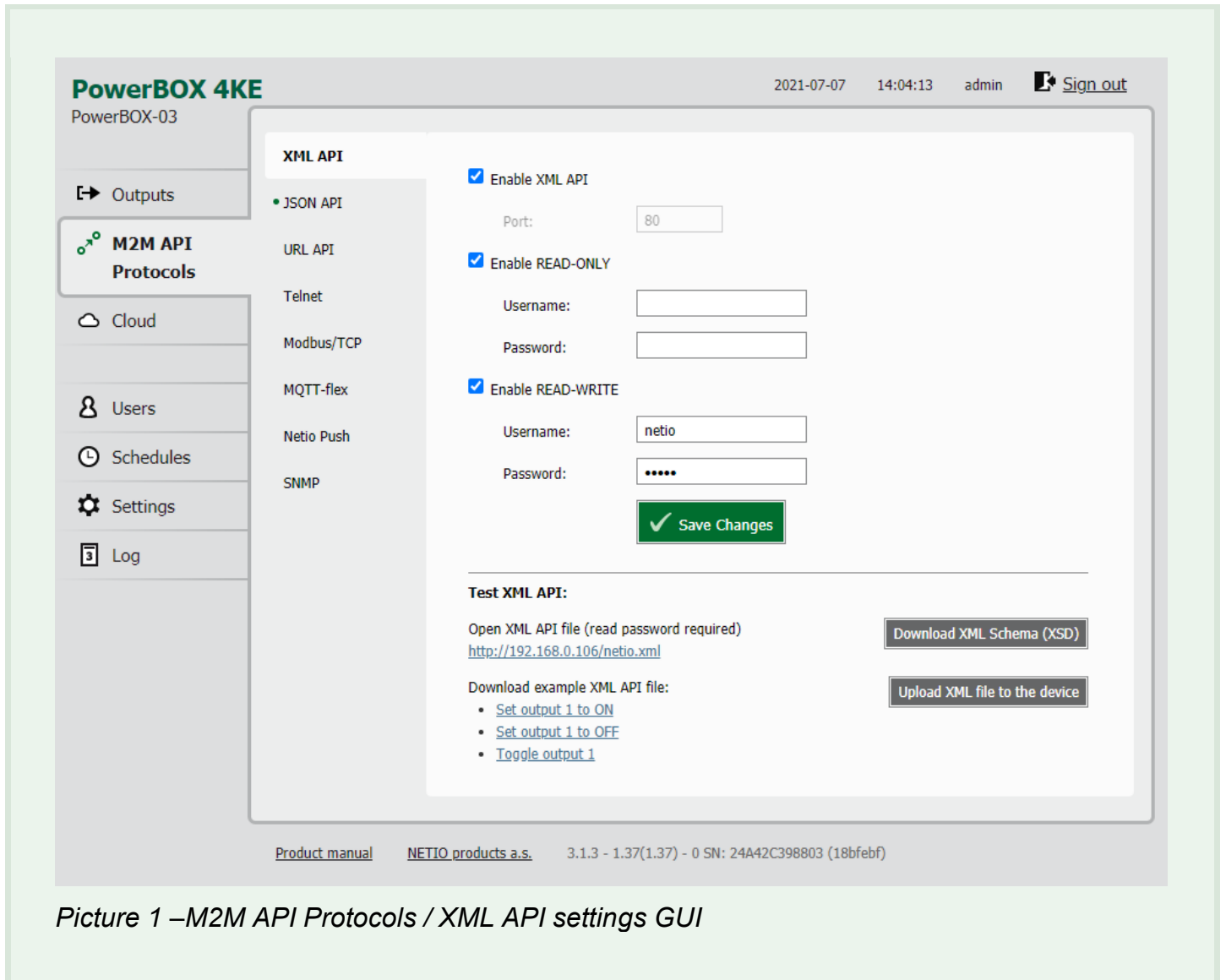

Picture 1 –M2M API Protocols / XML API settings GUI

- **Enable XML API** – Enable/disable the M2M API protocol
- **Enable READ-ONLY** – Enable READ functionality (HTTP(s) GET)
 - Username – Username for READ (default: no username)
 - Password – Password for READ (default: no password)
- **Enable WRITE-WRITE** – Enable READ-WRITE functionality (HTTP(s) POST)
 - Username – Username for READ-WRITE (default: netio)
 - Password – Password for READ-WRITE (default: netio)
- **Test XML API** – Link to netio.xml file for quick test/overview. READ functionality above must be enabled.

- **Download example XML API file** – examples of basic output actions
- **Download XML Schema (XSD)** – Show XML Schema (XSD)
- **Upload XML file to the device** – Functionality for manual XML file upload. Creates an HTTP(s) request with uploaded file and settings.

Notes

- **The device webserver is restarted after Saving of XML API settings.**
- Empty Username and Password means no authentication.
- Credentials are sent in the HTTP header, “Basic authentication” is used. The username and password can be also provided in the URL - `http(s)://username:password@<netioIP>/netio.xml`

NETIO XML protocol structure

XML API – READ (status)

HTTP(s) GET request or HTTP(s) POST request (no file or empty file)

GET Request: **`http(s)://<netioIP>/netio.xml`**

READ response (status netio.xml file):

```
<?xml version="1.0" encoding="utf-8"?>
<set:Root xmlns:set="http://www.netio-products.com/XMLSchema/NETIO.xsd">
  <Agent>
    <Model>4KE</Model>
    <DeviceName>PowerBOX-03</DeviceName>
    <OemID>500</OemID>
    <VendorID>0</VendorID>
    <Version>3.1.3</Version>
    <XmlVer>2.4</XmlVer>
    <SerialNumber>24A42C398803</SerialNumber>
    <MAC>24:A4:2C:39:88:03</MAC>
    <Uptime>9811</Uptime>
    <Time>2021-07-07T14:26:22+01:00</Time>
    <NumOutputs>4</NumOutputs>
    <NumInputs>0</NumInputs>
  </Agent>
  <GlobalMeasure>
    <OverallPowerFactor>999.00</OverallPowerFactor>
    <TotalPowerFactor>999.00</TotalPowerFactor>
  </GlobalMeasure>
</set:Root>
```

```
<Voltage>238.22</Voltage>
<OverallPhase>999.00</OverallPhase>
<TotalPhase>999.00</TotalPhase>
<Frequency>50.02</Frequency>
<TotalLoad>0</TotalLoad>
<TotalCurrent>0</TotalCurrent>
<TotalEnergy>0</TotalEnergy>
<TotalReverseEnergy>0</TotalReverseEnergy>
<TotalEnergyNR>5</TotalEnergyNR>
<TotalReverseEnergyNR>0</TotalReverseEnergyNR>
<EnergyStart>2021-06-17T16:42:18+01:00</EnergyStart>
</GlobalMeasure>
<Outputs>
  <Output>
    <ID>1</ID>
    <Name>Power output 1</Name>
    <State>1</State>
    <Action>6</Action>
    <Delay>5000</Delay>
    <PowerFactor>1.00</PowerFactor>
    <Phase>0.00</Phase>
    <Load>0</Load>
    <Current>0</Current>
    <Energy>0</Energy>
    <ReverseEnergy>0</ReverseEnergy>
    <EnergyNR>1</EnergyNR>
    <ReverseEnergyNR>0</ReverseEnergyNR>
  </Output>
  <Output>
    <ID>2</ID>
    <Name>Power output 2</Name>
    <State>1</State>
    <Action>6</Action>
    <Delay>5000</Delay>
    <PowerFactor>1.00</PowerFactor>
    <Phase>0.00</Phase>
    <Load>0</Load>
    <Current>0</Current>
    <Energy>0</Energy>
    <ReverseEnergy>0</ReverseEnergy>
    <EnergyNR>1</EnergyNR>
```

```

        <ReverseEnergyNR>0</ReverseEnergyNR>
</Output>
<Output>
  <ID>3</ID>
  <Name>Power output 3</Name>
  <State>1</State>
  <Action>6</Action>
  <Delay>5000</Delay>
  <PowerFactor>1.00</PowerFactor>
  <Phase>0.00</Phase>
  <Load>0</Load>
  <Current>0</Current>
  <Energy>0</Energy>
  <ReverseEnergy>0</ReverseEnergy>
  <EnergyNR>1</EnergyNR>
  <ReverseEnergyNR>0</ReverseEnergyNR>
</Output>
<Output>
  <ID>4</ID>
  <Name>Power output 4</Name>
  <State>1</State>
  <Action>6</Action>
  <Delay>5000</Delay>
  <PowerFactor>1.00</PowerFactor>
  <Phase>0.00</Phase>
  <Load>0</Load>
  <Current>0</Current>
  <Energy>0</Energy>
  <ReverseEnergy>0</ReverseEnergy>
  <EnergyNR>4</EnergyNR>
  <ReverseEnergyNR>0</ReverseEnergyNR>
</Output>
</Outputs>
<Inputs>
  <Input>
    <ID>1</ID>
    <Name>Input 1</Name>
    <State>0</State>
    <S0Counter>2309</S0Counter>
    <TemperatureC>25.3</TemperatureC>
    <TemperatureF>77.5</TemperatureF>

```

```
<Humidity>30</Humidity>
</Input>
<Input>
<ID>2</ID>
<Name>Input 2</Name>
<State>0</State>
<S0Counter>0</S0Counter>
<TemperatureC>999.0</TemperatureC>
<TemperatureF>999.0</TemperatureF>
<Humidity>9990</Humidity>
</Input>
</Inputs>
</set:Root>
```

Notes:

1. Items/values related to metering (Voltage, Frequency, Current, PowerFactor, Load and Energy, etc.) are available only for devices that have energy metering enabled

2. Returned status *netio.xml* file contains always "Action" with value "6" for all outputs. This value means "ignore" and works as a placeholder. Output state 0 / 1 is in the **State** value.

Values description

Global values:

"Model": "PowerBOX 4KE"	<i>Model identification</i>
"DeviceName": "myNetio_10"	<i>Device name (user defined on web)</i>
"OemID": 0	<i>Manufacturer internal use</i>
"VendorID": 0	<i>Manufacturer internal use</i>
"Version": "3.1.3"	<i>Firmware version</i>
"XmlVer": "2.4"	<i>Protocol version</i>
"SerialNumber": "24A42C332510"	<i>Serial Number of device – preferred identifier (identical with label on delivery box).</i>
"MAC": "24:A4:2C:33:25:10"	<i>MAC address of active interface.</i>
	<i>For LAN/WIFI devices only.</i>
"Uptime": 110637	[s] <i>The Uptime value</i>
"Time": "2017-11-03T13:53:38+00:00"	<i>Date and time of the NETIO device</i>
"NumOutputs": 4	<i>Number of outputs</i>
"NumInputs": 0	<i>Number of inputs</i>
"OverallPowerFactor": 999.00	<i>Historical compatibility – do not use</i>
"TotalPowerFactor": 999.00	<i>Instantaneous True Power Factor – weighted average from all meters</i>
"Voltage": 235.8	[V] <i>Instantaneous voltage</i>
"OverallPhase": 999.00	<i>Historical compatibility – do not use</i>
"TotalPhase": 999.00	[°] <i>Instantaneous Phase weighted average from all meters</i>
"Frequency": 49.9	[Hz] <i>Instantaneous frequency</i>
"TotalLoad": 1	[W] <i>Total Power of all power outputs</i>
"TotalCurrent": 20	[mA] <i>Instantaneous total current through all power outputs</i>
"TotalEnergy": 965	[Wh] <i>Counter of total consumed Energy (4B)</i>
"TotalReverseEnergy": 1	[Wh] <i>Counter of total produced Energy (4B)</i>
"TotalEnergyNR": 2530	[Wh] <i>Not resettable counter of total consumed Energy (4B)</i>
"TotalReverseEnergyNR": 8	[Wh] <i>Not resettable counter of total produced Energy (4B)</i>
"EnergyStart": "2017-06-23T16:47:53+01:00"	<i>Date and time of the last reset of all energy counters</i>

Values for specific output (example values below are for output 4):

"ID": 4	<i>Output number</i>
"Name": "output_4"	<i>Output name (user defined on web)</i>
"State": 1	<i>Output state</i>
"Action": 6	<i>Output action (6 = Ignored value, use State tag)</i>
"Delay": 5000	<i>[ms] Output delay for short On/Off</i>
"PowerFactor": 0.22	<i>[-] Instantaneous True Power Factor</i>
"Phase": -30.81	<i>[°] Instantaneous Phase of the output</i>
"Load": 1	<i>[W] Total Power of the output</i>
"Current": 20	<i>[mA] Instantaneous current of the output</i>
"Energy": 965	<i>[Wh] Counter of output consumed Energy (4B)</i>
"ReverseEnergy": 1	<i>[Wh] Counter of output produced Energy (4B)</i>
"EnergyNR": 2530	<i>[Wh] Not resettable counter of consumed Energy (4B)</i>
"ReverseEnergyNR": 8	<i>[Wh] Not resettable counter of output produced Energy (4B)</i>

Values for specific input (example values below are for input 2):

"ID": 2	<i>Input number</i>
"Name": "Input 2"	<i>Input name</i>
"State": 0	<i>Input state (0 = OFF/"open", 1 = ON/"closed")</i>
"S0Counter": 25	<i>S0 Counter value (4B)</i>
"TemperatureC": 25	<i>Temperature 25C</i>
"TemperatureF": 71	<i>Temperature 71F</i>
"Humidity": 30	<i>Humidity 30%</i>

*** in case no sensor connection - variation will display 9990
<TemperatureC>999.0</TemperatureC>
<TemperatureF>999.0</TemperatureF>
<Humidity>9990</Humidity>
*** -----***

XML API – WRITE (control)

HTTP(s) POST request

ID - number of output

Outputs can be controlled by two options:

- 1. Action:** 0 – off, 1 – on, 2 – short off, 3 – short on, 4 – toggle, 5 – no change, (6 – ignore)
- 2. State:** 0 – off, 1 – on (Action = 6 required)

Note: **Action** with other value than 6 has higher priority than the **State** tag.
State value is not reflected in case Action = 1 to 5.
If you wish to use **State** tag to control an output, **Action = 6 is required**.

XML file can be submitted as complete structure (e.g. previously received status XML with modified control functions) or partial structure as shown below.

If the XML & command is accepted, then NETIO returns Status Code "200 OK" and status XML file.

POST Request: **http(s)://<netioIP>/netio.xml**

Switch Power output 1 to ON by Action tag:

```
<set:Root xmlns:set="http://www.netio-products.com/XMLSchema/NETIO.xsd">
  <Outputs>
    <Output>
      <ID>1</ID>
      <Action>1</Action>
    </Output>
  </Outputs>
</set:Root>
```

or (State tag value will not be reflected)

```
<set:Root xmlns:set="http://www.netio-products.com/XMLSchema/NETIO.xsd">
  <Outputs>
    <Output>
      <ID>1</ID>
      <State>0</State>
      <Action>1</Action>
    </Output>
  </Outputs>
</set:Root>
```

or by State tag (Action tag must have value 6)

```
<set:Root xmlns:set="http://www.netio-products.com/XMLSchema/NETIO.xsd">
  <Outputs>
    <Output>
```

```
<ID>1</ID>  
<State>1</State>  
<Action>6</Action>  
</Output>  
</Outputs>  
</set:Root>
```

Switch Power output 2 to ON for 15 second, then switch it OFF.

```
<set:Root xmlns:set="http://www.netio-products.com/XMLSchema/NETIO.xsd">
  <Outputs>
    <Output>
      <ID>2</ID>
      <Action>3</Action>
      <Delay>15000</Delay>
    </Output>
  </Outputs>
</set:Root>
```

More outputs control command:

Switch Power output 1 to ON, Invert state of Output 2 and Switch Output 4 to ON for 10 seconds:

```
<set:Root xmlns:set="http://www.netio-products.com/XMLSchema/NETIO.xsd">
  <Outputs>
    <Output>
      <ID>1</ID>
      <State>1</State>
      <Action>6</Action>
    </Output>
    <Output>
      <ID>2</ID>
      <Action>4</Action>
    </Output>
    <Output>
      <ID>4</ID>
      <Action>3</Action>
      <Delay>10000</Delay>
    </Output>
  </Outputs>
</set:Root>
```

HTTP status codes

Status codes	Description
200 OK	User authorized and command executed
400 Bad Request	Control command syntax error
401 Unauthorized	Invalid Username or Password
403 Forbidden	Read only or XML M2M API not enabled
500 Internal Server Error	Internal Server Error or Internal Server not fully started yet (e.g. after setting change or restart)

Response syntax for “OK” state:

Status XML file as described above in chapter “NETIO XML protocol structure” / READ

Response syntax for “Error” state:

```
<Result>  
  <Error Code="400">Bad request</Error>  
</Result>
```

NETIO AN (Application Note)

AN20: XML HTTP(s) protocol to control NETIO smart power sockets 110/230V

The AN20 Application Note demonstrates how to control NETIO 4x smart sockets using the XML protocol. The XML protocol transfers a text file with a xml structure over http(s). NETIO devices contain built-in tools to easily test the protocol by the user. The XML protocol is supported by all NETIO devices.

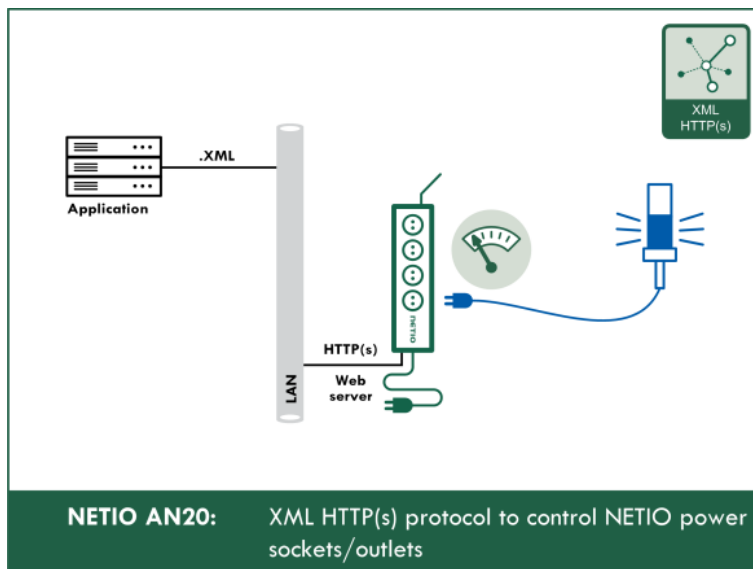

>> Read the AN20 on www.netio-products.com

NETIO PowerBOX 3Px – listing of the XML file

- Device without energy metering

```
<?xml version="1.0" encoding="utf-8"?>
<set:Root xmlns:set="http://www.netio-products.com/XMLSchema/NETIO.xsd">
  <Agent>
    <Model>4KE</Model>
    <DeviceName>PowerBOX-03</DeviceName>
    <OemID>500</OemID>
    <VendorID>0</VendorID>
    <Version>3.1.3</Version>
    <XmlVer>2.4</XmlVer>
    <SerialNumber>24A42C398803</SerialNumber>
    <MAC>24:A4:2C:39:88:03</MAC>
    <Uptime>9811</Uptime>
    <Time>2021-07-07T14:26:22+01:00</Time>
    <NumOutputs>4</NumOutputs>
    <NumInputs>0</NumInputs>
  </Agent>
</set:Root>
```

```
</Agent>
<GlobalMeasure>
  <OverallPowerFactor>999.00</OverallPowerFactor>
  <TotalPowerFactor>999.00</TotalPowerFactor>
  <Voltage>238.22</Voltage>
  <OverallPhase>999.00</OverallPhase>
  <TotalPhase>999.00</TotalPhase>
  <Frequency>50.02</Frequency>
  <TotalLoad>0</TotalLoad>
  <TotalCurrent>0</TotalCurrent>
  <TotalEnergy>0</TotalEnergy>
  <TotalReverseEnergy>0</TotalReverseEnergy>
  <TotalEnergyNR>5</TotalEnergyNR>
  <TotalReverseEnergyNR>0</TotalReverseEnergyNR>
  <EnergyStart>2021-06-17T16:42:18+01:00</EnergyStart>
</GlobalMeasure>
<Outputs>
  <Output>
    <ID>1</ID>
    <Name>Power output 1</Name>
    <State>1</State>
    <Action>6</Action>
    <Delay>5000</Delay>
    <PowerFactor>1.00</PowerFactor>
    <Phase>0.00</Phase>
    <Load>0</Load>
    <Current>0</Current>
    <Energy>0</Energy>
    <ReverseEnergy>0</ReverseEnergy>
    <EnergyNR>1</EnergyNR>
    <ReverseEnergyNR>0</ReverseEnergyNR>
  </Output>
  <Output>
    <ID>2</ID>
    <Name>Power output 2</Name>
    <State>1</State>
    <Action>6</Action>
    <Delay>5000</Delay>
    <PowerFactor>1.00</PowerFactor>
    <Phase>0.00</Phase>
    <Load>0</Load>
```

```

    <Current>0</Current>
    <Energy>0</Energy>
    <ReverseEnergy>0</ReverseEnergy>
    <EnergyNR>1</EnergyNR>
    <ReverseEnergyNR>0</ReverseEnergyNR>
</Output>
<Output>
    <ID>3</ID>
    <Name>Power output 3</Name>
    <State>1</State>
    <Action>6</Action>
    <Delay>5000</Delay>
    <PowerFactor>1.00</PowerFactor>
    <Phase>0.00</Phase>
    <Load>0</Load>
    <Current>0</Current>
    <Energy>0</Energy>
    <ReverseEnergy>0</ReverseEnergy>
    <EnergyNR>1</EnergyNR>
    <ReverseEnergyNR>0</ReverseEnergyNR>
</Output>
<Output>
    <ID>4</ID>
    <Name>Power output 4</Name>
    <State>1</State>
    <Action>6</Action>
    <Delay>5000</Delay>
    <PowerFactor>1.00</PowerFactor>
    <Phase>0.00</Phase>
    <Load>0</Load>
    <Current>0</Current>
    <Energy>0</Energy>
    <ReverseEnergy>0</ReverseEnergy>
    <EnergyNR>4</EnergyNR>
    <ReverseEnergyNR>0</ReverseEnergyNR>
</Output>
</Outputs>
</set:Root>

```

NETIO PowerPDU 8QS – listing of the XML file

- Device with Total energy metering (for all outputs)
- Device with energy metering on Output 1.

```
<set:Root
  xmlns:set="http://www.netio-products.com/XMLSchema/NETIO.xsd">
  <Agent>
    <Model>8QS</Model>
    <DeviceName>DJ-8QS-TEST</DeviceName>
    <OemID>600</OemID>
    <VendorID>0</VendorID>
    <Version>3.1.6</Version>
    <XmlVer>2.4</XmlVer>
    <SerialNumber>24A42C39ABC1</SerialNumber>
    <MAC>24:A5:2C:39:AB:C1</MAC>
    <Uptime>1081</Uptime>
    <Time>2021-07-20T16:40:29+01:00</Time>
    <NumOutputs>8</NumOutputs>
    <NumInputs>1</NumInputs>
  </Agent>
  <GlobalMeasure>
    <OverallPowerFactor>1.00</OverallPowerFactor>
    <TotalPowerFactor>1.00</TotalPowerFactor>
    <Voltage>238.36</Voltage>
    <OverallPhase>0.00</OverallPhase>
    <TotalPhase>0.00</TotalPhase>
    <Frequency>50.00</Frequency>
    <TotalLoad>0</TotalLoad>
    <TotalCurrent>0</TotalCurrent>
    <TotalEnergy>0</TotalEnergy>
    <TotalReverseEnergy>0</TotalReverseEnergy>
    <TotalEnergyNR>0</TotalEnergyNR>
    <TotalReverseEnergyNR>0</TotalReverseEnergyNR>
    <EnergyStart>1970-01-01T00:00:00+01:00</EnergyStart>
  </GlobalMeasure>
  <Outputs>
    <Output>
      <ID>1</ID>
      <Name>Power output 1</Name>
      <State>0</State>
      <Action>6</Action>
    </Output>
  </Outputs>
</set:Root>
```

```
<Delay>5000</Delay>
<PowerFactor>1.00</PowerFactor>
<Phase>0.00</Phase>
<Load>0</Load>
<Current>0</Current>
<Energy>0</Energy>
<ReverseEnergy>0</ReverseEnergy>
<EnergyNR>0</EnergyNR>
<ReverseEnergyNR>0</ReverseEnergyNR>
</Output>
<Output>
  <ID>2</ID>
  <Name>Power output 2</Name>
  <State>0</State>
  <Action>6</Action>
  <Delay>5000</Delay>
</Output>
<Output>
  <ID>3</ID>
  <Name>Power output 3</Name>
  <State>0</State>
  <Action>6</Action>
  <Delay>5000</Delay>
</Output>
<Output>
  <ID>4</ID>
  <Name>Power output 4</Name>
  <State>0</State>
  <Action>6</Action>
  <Delay>5000</Delay>
</Output>
<Output>
  <ID>5</ID>
  <Name>Power output 5</Name>
  <State>0</State>
  <Action>6</Action>
  <Delay>5000</Delay>
</Output>
<Output>
  <ID>6</ID>
  <Name>Power output 6</Name>
```

```
<State>0</State>
<Action>6</Action>
<Delay>5000</Delay>
</Output>
<Output>
  <ID>7</ID>
  <Name>Power output 7</Name>
  <State>0</State>
  <Action>6</Action>
  <Delay>5000</Delay>
</Output>
<Output>
  <ID>8</ID>
  <Name>Power output 8</Name>
  <State>1</State>
  <Action>6</Action>
  <Delay>5000</Delay>
</Output>
</Outputs>
<Inputs>
  <Input>
    <ID>1</ID>
    <Name>Input 1</Name>
    <State>0</State>
    <S0Counter>0</S0Counter>
  </Input>
</Inputs>
</set:Root>
```

NETIO PowerPDU 4C – listing of the xml file

- Device with energy metering on every one Output
- Linux based devices (tiny differences in <CR><LF>can be expected

```
<set:Root
  xmlns:set="http://www.netio-products.com/XMLSchema/NETIO.xsd">
  <Agent>
    <Model>PowerPDU 4C</Model>
    <Version>3.4.1</Version>
    <XmlVer>2.1</XmlVer>
    <DeviceName>DJ-4C-TEST</DeviceName>
    <VendorID>0</VendorID>
    <OemID>0</OemID>
    <SerialNumber/>
    <Uptime>344823</Uptime>
    <Time>2021-07-19T17:22:56+03:00</Time>
    <NumOutputs>4</NumOutputs>
  </Agent>
  <GlobalMeasure>
    <Voltage>236.6</Voltage>
    <Frequency>50.0</Frequency>
    <TotalCurrent>0</TotalCurrent>
    <OverallPowerFactor>0.00</OverallPowerFactor>
    <TotalLoad>0</TotalLoad>
    <TotalEnergy>1257</TotalEnergy>
    <EnergyStart>2020-04-24T10:50:20+03:00</EnergyStart>
  </GlobalMeasure>
  <Outputs>
    <Output>
      <ID>1</ID>
      <Name>output_1</Name>
      <State>0</State>
      <Action>6</Action>
      <Delay>5000</Delay>
      <Current>0</Current>
      <PowerFactor>0.00</PowerFactor>
      <Load>0</Load>
      <Energy>1206</Energy>
    </Output>
    <Output>
      <ID>2</ID>
```

```
<Name>output_2</Name>
<State>0</State>
<Action>6</Action>
<Delay>5000</Delay>
<Current>0</Current>
<PowerFactor>0.00</PowerFactor>
<Load>0</Load>
<Energy>1</Energy>
</Output>
<Output>
  <ID>3</ID>
  <Name>output_3</Name>
  <State>0</State>
  <Action>6</Action>
  <Delay>5000</Delay>
  <Current>0</Current>
  <PowerFactor>0.00</PowerFactor>
  <Load>0</Load>
  <Energy>28</Energy>
</Output>
<Output>
  <ID>4</ID>
  <Name>output_4</Name>
  <State>0</State>
  <Action>6</Action>
  <Delay>5000</Delay>
  <Current>0</Current>
  <PowerFactor>0.00</PowerFactor>
  <Load>0</Load>
  <Energy>21</Energy>
</Output>
</Outputs>
</set:Root>
```

XML Schema (XSD)

NETIO.xsd

```
<?xml version="1.0" encoding="utf-8"?>
<xs:schema
  targetNamespace="http://www.netio-products.com/XMLSchema/NETIO.xsd"
  xmlns:set="http://www.netio-products.com/XMLSchema/NETIO.xsd"
  xmlns:xs="http://www.w3.org/2001/XMLSchema">
  <xs:element name="Root" type="set:RootType"/>
  <xs:complexType name="RootType">
    <xs:sequence>
      <xs:element name="Agent" minOccurs="0" maxOccurs="1">
        <xs:complexType>
          <xs:all>
            <xs:element name="Model" type="xs:string" minOccurs="0" maxOccurs="1" />
            <xs:element name="Version" type="xs:string" minOccurs="0" maxOccurs="1" />
            <xs:element name="XmlVer" type="xs:string" minOccurs="0" maxOccurs="1" />
            <xs:element name="DeviceName" type="xs:string" minOccurs="0" maxOccurs="1" />
            <xs:element name="VendorID" type="xs:unsignedInt" minOccurs="0" maxOccurs="1" />
            <xs:element name="OemID" type="xs:unsignedInt" minOccurs="0" maxOccurs="1" />
            <xs:element name="SerialNumber" type="xs:string" minOccurs="0" maxOccurs="1" />
            <xs:element name="MAC" type="xs:string" minOccurs="0" maxOccurs="1" />
            <xs:element name="Uptime" type="xs:unsignedInt" minOccurs="0" maxOccurs="1" />
            <xs:element name="Time" type="xs:dateTime" minOccurs="0" maxOccurs="1" />
            <xs:element name="NumOutputs" type="xs:unsignedInt" minOccurs="0" maxOccurs="1" />
            <xs:element name="NumInputs" type="xs:unsignedInt" minOccurs="0" maxOccurs="1" />
          </xs:all>
        </xs:complexType>
      </xs:element>
      <xs:element name="GlobalMeasure" minOccurs="0" maxOccurs="1">
        <xs:complexType>
          <xs:all>
            <xs:element name="Voltage" type="xs:double" minOccurs="0" maxOccurs="1" />
            <xs:element name="Frequency" type="xs:double" minOccurs="0" maxOccurs="1" />
            <xs:element name="TotalCurrent" type="xs:unsignedLong" minOccurs="0" maxOccurs="1" />
            <xs:element name="OverallPowerFactor" type="xs:double" minOccurs="0" maxOccurs="1" />
            <xs:element name="TotalPowerFactor" type="xs:double" minOccurs="0" maxOccurs="1" />
            <xs:element name="TotalPhase" type="xs:double" minOccurs="0" maxOccurs="1" />
            <xs:element name="OverallPhase" type="xs:double" minOccurs="0" maxOccurs="1" />
            <xs:element name="TotalReverseEnergy" type="xs:unsignedLong" minOccurs="0" maxOccurs="1" />
            <xs:element name="TotalEnergyNR" type="xs:unsignedLong" minOccurs="0" maxOccurs="1" />
            <xs:element name="TotalReverseEnergyNR" type="xs:unsignedLong" minOccurs="0" maxOccurs="1" />
          </xs:all>
        </xs:complexType>
      </xs:element>
    </xs:sequence>
  </xs:complexType>
</xs:schema>
```

```

        <xs:element name="TotalLoad" type="xs:int" minOccurs="0" maxOccurs="1" />
        <xs:element name="TotalEnergy" type="xs:unsignedLong" minOccurs="0" maxOccurs="1" />
        <xs:element name="EnergyStart" type="xs:dateTime" minOccurs="0" maxOccurs="1" />
    </xs:all>
</xs:complexType>
</xs:element>
<xs:element name="Outputs" minOccurs="0" maxOccurs="1">
    <xs:complexType>
        <xs:sequence>
            <xs:element name="Output" minOccurs="0" maxOccurs="unbounded">
                <xs:complexType>
                    <xs:all>
                        <xs:element name="ID" type="xs:unsignedInt" minOccurs="0" maxOccurs="1" />
                        <xs:element name="Name" type="xs:string" minOccurs="0" maxOccurs="1" />
                        <xs:element name="State" type="xs:unsignedInt" minOccurs="0" maxOccurs="1" />
                        <xs:element name="Action" type="xs:unsignedInt" minOccurs="0" maxOccurs="1" />
                        <xs:element name="Delay" type="xs:unsignedInt" minOccurs="0" maxOccurs="1" />
                        <xs:element name="Current" type="xs:unsignedInt" minOccurs="0" maxOccurs="1" />
                        <xs:element name="PowerFactor" type="xs:double" minOccurs="0" maxOccurs="1" />
                        <xs:element name="Phase" type="xs:double" minOccurs="0" maxOccurs="1" />
                        <xs:element name="Load" type="xs:int" minOccurs="0" maxOccurs="1" />
                        <xs:element name="Energy" type="xs:unsignedLong" minOccurs="0" maxOccurs="1" />
                        <xs:element name="ReverseEnergy" type="xs:unsignedLong" minOccurs="0" maxOccurs="1" />
                        <xs:element name="ReverseEnergyNR" type="xs:unsignedLong" minOccurs="0" maxOccurs="1" />
                        <xs:element name="EnergyNR" type="xs:unsignedLong" minOccurs="0" maxOccurs="1" />
                    </xs:all>
                </xs:complexType>
            </xs:element>
        </xs:sequence>
    </xs:complexType>
</xs:element>
<xs:element name="Inputs" minOccurs="0" maxOccurs="1">
    <xs:complexType>
        <xs:sequence>
            <xs:element name="Input" minOccurs="0" maxOccurs="unbounded">
                <xs:complexType>
                    <xs:all>
                        <xs:element name="ID" type="xs:unsignedInt" minOccurs="0" maxOccurs="1" />
                        <xs:element name="Name" type="xs:string" minOccurs="0" maxOccurs="1" />
                        <xs:element name="State" type="xs:unsignedInt" minOccurs="0" maxOccurs="1" />
                        <xs:element name="S0Counter" type="xs:unsignedInt" minOccurs="0" maxOccurs="1" />
                    </xs:all>
                </xs:complexType>
            </xs:element>
        </xs:sequence>
    </xs:complexType>
</xs:element>

```

```

        </xs:all>
        </xs:complexType>
        </xs:element>
        </xs:sequence>
        </xs:complexType>
        </xs:element>
        </xs:sequence>
        </xs:complexType>
</xs:schema>

```

Document history

Document Revision	Publication Date	Description
1.0	3.11.2017	Initial release for FW 3.0.1 beta (nff5504c)
1.1	14.11.2017	Minor updates & changes. XML Version 2.0, for FW 3.0.1
1.2	19.12.2017	Documentation optimization - Action 6, Keywords added.
1.3	23.2.2018	Minor updates
1.6	16.10.2018	Values description updated, Infographic added
1.7	16.10.2018	AN20 description added
1.8	23.11.2018	Detailed description about the Action tag implemented
2.0	29.1.2020	MAC added; protocol version increased
2.1	7.7.2021	XML version 2.4, energy metering and XML attributes description updated, XML schema updated
2.4	24.02.2025	Adding Temperature, Humidity